

# HL 186

# HP 9,6

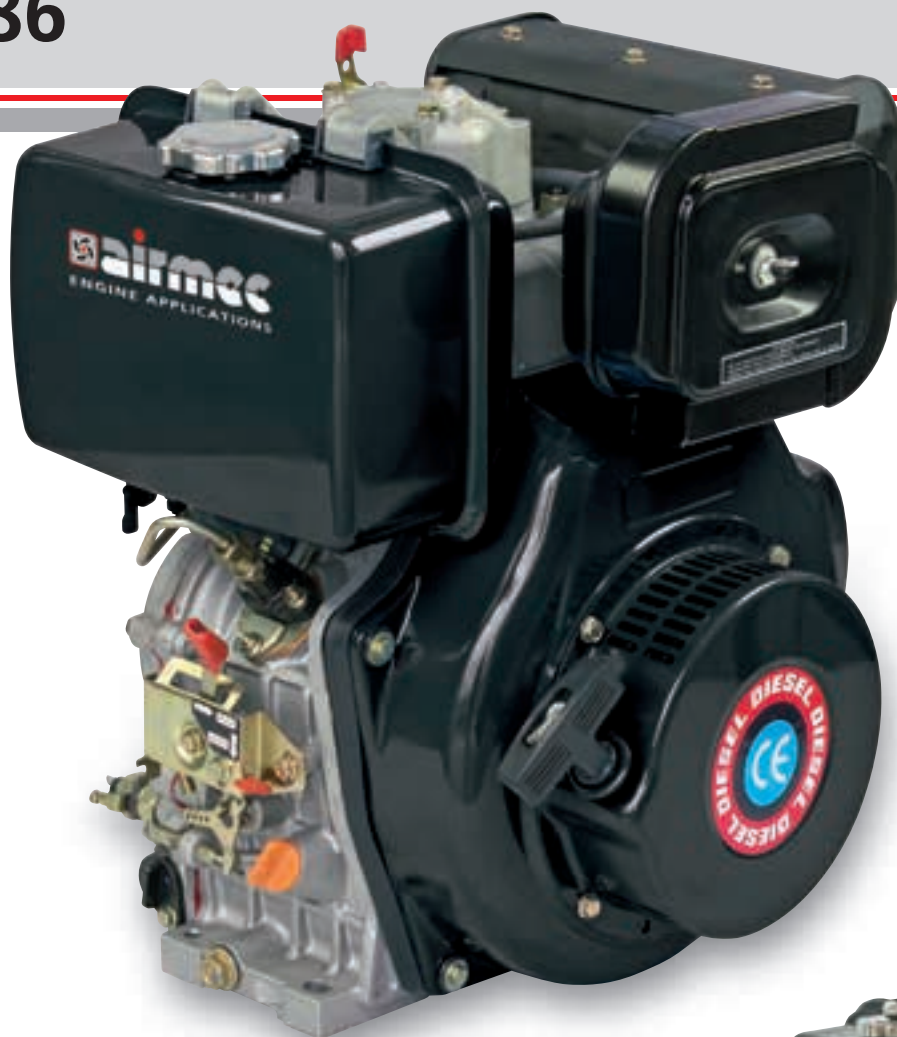

POWERED by  
**HAILIN**  
diesel expert

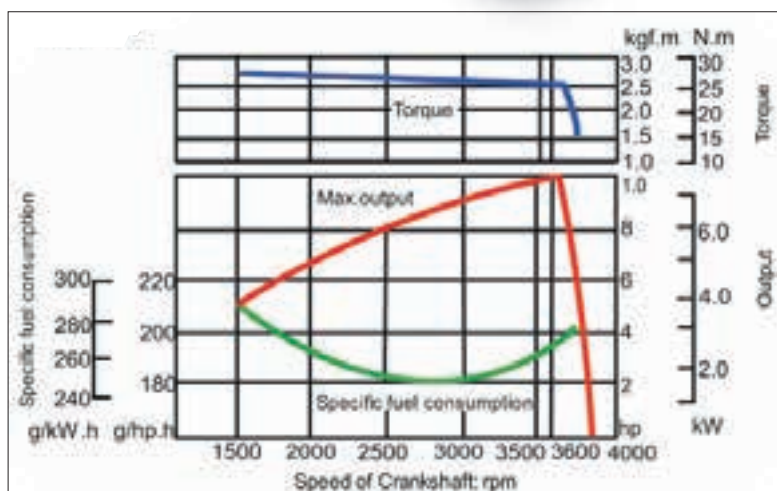

HL 186 FA G4-L

## MOTORE - ENGINE

Carburante <i>Fuel</i>	Max. potenza resa <i>Max. output</i>	Potenza uso continuo <i>Continuos output</i>	Sistema avviamento <i>Starting system</i>	Cilindrata <i>Displacement</i>	Giri motore <i>Engine speed</i>
type	HP	HP	type	cc	r.p.m.
<b>Diesel</b>	9,6	8,6	manuale - elettrico <i>recoil - electric</i>	418	3600

Capacità serbatoio <i>Tank capacity</i>	Capacità serbatoio olio <i>Oil tank capacity</i>	Rumorosità <i>Noise</i>	Alesaggio corsa <i>Bore Stroke</i>	Dimensioni <i>Dimensions</i>	Peso a secco <i>Dry weight</i>
lt	lt	≤7m dB (A)	mm	mm	Kg
5,5	1,65	85	86 x 72	417 x 470 x 494	53

## VERSIONE / VERSIONS



Albero conico D. 23  
Type shaft

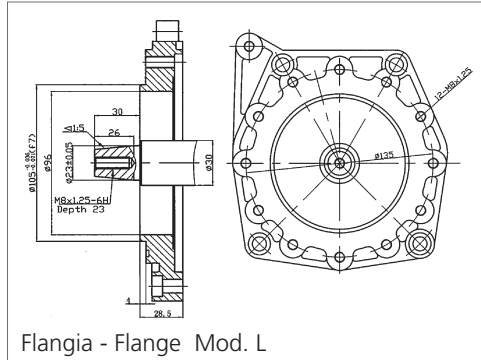

Flangia - Flange Mod. L

### HL 186 FA-G4 L

- Albero Conico D.23
- Avviamento Manuale
- Filtro Aria bagno olio



Albero conico D. 23  
Type shaft

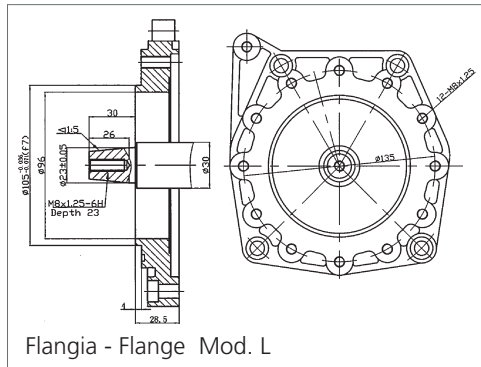

Flangia - Flange Mod. L

### HL 186 FA-E G4 L

- Albero Conico D.23
- Avviamento Elettico
- Filtro Aria bagno olio



Albero cilindrico D. 25.4  
Cilindric shaft

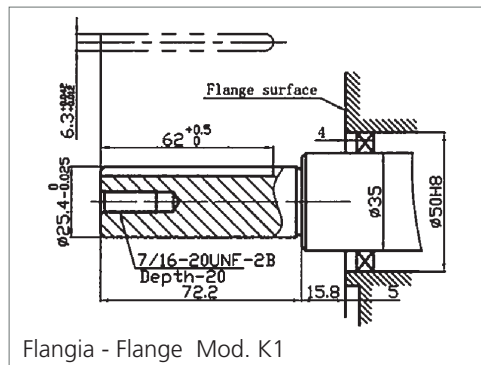

Flangia - Flange Mod. K1

### HL 186 FA-E K1

- Albero Cilindrico D.25.4
- Avviamento Elettico
- Filtro Aria secco



Albero lungo generatore  
Generator shaft

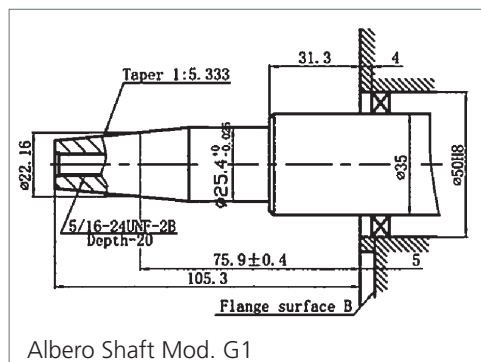

Albero Shaft Mod. G1

### HL 186 FA-E G1

- Albero lungo generatore
- Avviamento Elettico
- Filtro Aria secco